



Reliance Industries, LLC

Installation, Operation, Inspection and Maintenance Instructions for the Skyline™ Horizontal Lifeline System

6360

Portable Looped Rebar Lifeline System using 3/8 – 7x19 Steel Wire Rope with Ratchet Tensioner and the Skyline™ Shock Absorber

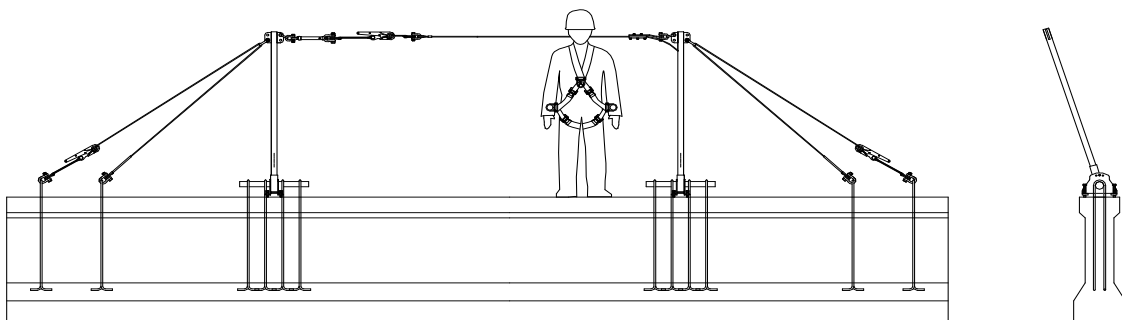

**PO Box 140008
Denver, CO 80214
Ph. (800) 488-5751
Ph. (303) 424-8650
Fax (303) 424-8670**

US Patent #6,338,399 and other Patents Pending

User Instructions

6360 Skyline™ Looped Rebar HLL System



Important Instructions!

These instructions must be kept on file and available for the users reference at **all** times. The users must read and full understand these instructions or have the instructions explained in detail before using this equipment. **Failure to observe these instructions could result in serious injury or death.**

Prior to use, all workers must be trained in the proper use of all systems and equipment.

A Training and Instruction review should be repeated at regular intervals.

A rescue plan must be prepared; the workers must be trained in its use, and rescue equipment must be on hand prior to any use of this horizontal lifeline system.

Any questions regarding these instructions should be directed to:

Reliance Industries, LLC
PO Box 140008
Denver, CO 80214
Ph. (800) 488-5751
Ph. (303) 424-8650
Fax (303) 424-8670

Table of Contents

IMPORTANT INSTRUCTIONS! 2

SYSTEM DESCRIPTION 5

ANCHORAGE POINTS 6

HORIZONTAL LIFELINE SYSTEM COMPONENTS 6

PERSONAL FALL ARREST EQUIPMENT USED WITH HORIZONTAL LIFELINES 7

INSTALLATION LAYOUT CONSIDERATIONS 7

INSTALLATION 8

HLL INSTALLATION PROCEDURES 9

 TO INSTALL THE LOOPED REBAR RECEIVER 9

 TO INSTALL THE TIE-BACK STRAP ASSEMBLIES 10

 TO INSTALL THE SKYLINE™ HORIZONTAL LIFELINE 11

TRAINING 16

PLANNING FOR RESCUE 16

INSPECTION 17

SERVICING 17

WARNINGS AND LIMITATIONS 18

INSPECTION LOG FOR HLL SYSTEMS 19

SKYLINE™ HORIZONTAL LIFELINE DIAGRAM 20

User Instructions

6360 Skyline™ Looped Rebar HLL System



Important OSHA Regulations Covering the Use of Horizontal Lifeline Systems

OSHA 1910.66 Subpart M – 1926.502 (d)(8):

Horizontal Lifelines shall be designed, installed, and used under the supervision of a qualified person as part of a complete fall arrest system which maintains a safety factor of at least two.

OSHA 1910.66 (b):

“Qualified Person” means one with a recognized degree or professional certificate and extensive knowledge and experience in the subject field who is capable of design, analysis, evaluation, and specifications in the subject work, project, or product.

OSHA 1910.66 (b):

“Competent Person” means a person who is capable of identifying hazardous or dangerous conditions in the personal fall arrest system or any component thereof, as well as in their application and use with related equipment

OSHA 1910.66:

Personal fall arrest systems shall be rigged such that an employee can neither free-fall more than 6-ft. nor contact any lower surface.

OSHA 1910.66 (n):

The sag in the lifeline should be minimized to prevent the connecting piece of equipment (self-retracting lanyard or other appropriate personal fall arrest device) from sliding down the lifeline to a position which creates a swing hazard during a fall arrest.

OSHA Standards, Interpretations and Compliance Letters, 02/09/1995-Criteria for personal fall arrest systems:

The free-fall distance is limited to 6 feet. The deceleration distance must not exceed 42 inches; lifeline elongation is not included in deceleration distance; and the total fall distance is unregulated except that the employee cannot make contact with a lower level...The safety factor of two should be applied based on the anticipated maximum arrest force, not the fall energy.

User Instructions

6360 Skyline™ Looped Rebar HLL System



System Description

The Skyline™ Horizontal Lifeline System P/N 6360 is designed for use as a portable horizontal lifeline system where looped rebar structures encased in concrete are present, such as bridge construction. Its' lightweight materials allow for easy installation and removal, yet the rugged construction allows for a long service life in demanding construction environments. The lifeline is constructed of 3/8"– 7x19 wire rope and is available in both galvanized (IPS) and stainless steel versions and uses a unique ratchet load binder to enable rapid tensioning of the Skyline™ lifeline to the proper load. It is designed to allow the user to erect an engineered fall arrest system in work areas where no overhead anchor points exist. The system, in general, is designed for use by up to 4 persons at the same time, and can span distances up to 200 ft. However, span length and number of persons on the system determine input energy (and therefore, final line tension) and not all combinations of span lengths and number of workers are possible. The user must consult the manufacturer for exact system parameters for each installation, or in the event that the system is moved. System parameters are provided in the form of computer-generated load and Minimum Required Clearance (MRC) data that is traceable to our data and actual test results for each system installation.

The computer generated designs are prepared from verifiable test data and include a 2 ft. safety factor for Minimum Required Clearance, and a 2 to 1 or greater Safety Factor over the minimum cable breaking strength for maximum allowable line tension.

This system design is predicated on the use of a full-body harness for the worker, double-action, single-locking snap hooks to attach to the lifeline, and a shock absorbing vertical lifeline or self-retracting lanyard (SRL) with 900 lb. maximum arrest force. Non-shock absorbing lanyards and retractables that **DO NOT** limit fall arrest forces to 900-lb. or less (fall arrest devices that do not have "slip-clutch" type internal shock absorbers, or tear-away webbing shock absorbers with 900 lb. maximum MAF) are **NOT** allowed for use as vertical lifelines on this system. Any attachment to the horizontal lifeline must transfer fall arrest forces to the body through the dorsal d-ring of the full body harness only. Harness side and chest d-rings are not allowable lanyard connection points.

All Skyline™ HLL systems are supplied with an integral shock absorber in the line and no system may be used without one. The four main functions of the shock absorber are:

1. It adds energy capacity to the system to increase the safety of short horizontal lifelines.
2. It adds hysteresis (friction) to the system to absorb rebound energy.
3. It decreases low sag angle amplification by controllably elongating the horizontal lifeline.
4. It allows the cable to be tuned (or pre-loaded to a higher initial line tension) to force the cable to absorb energy at a higher rate.

The shock absorber has a built in spring-loaded tensioner that indicates when the proper pre-tension has been achieved. Normally the pre-tension is set at 1000-lb. but may be changed for specifically designed applications.

User Instructions

6360 Skyline™ Looped Rebar HLL System



When a system is installed, the pre-tension must be set according to the installation instructions. Not all systems are perfectly rigid; therefore, pre-tension may change over time. Prior to each use, the worker must check the pre-tension of the system and adjust it accordingly. When the pre-tension of a system is closely controlled, the fall distance and final line tension are easily predictable. Knowing that the pre-tension of a horizontal lifeline is set correctly is of utmost importance to the predictability and safety of the system.

Anchorage Points

The strength of horizontal lifeline anchorage points must be at least two times the anticipated line tension. This strength must be certified by a qualified person and must be verifiable by either calculation or testing. Anchorage connectors must be selected carefully. Eyebolts should not be used if they will be loaded at an angle to their axis, unless the loads fall within design parameters for such use. Weld-on lugs should not be less than ½ inch in material thickness and should not be made of steel with less than 50,000-PSI yield strength. The proper stress areas and weld areas must be calculated to assure proper safety. If in question, consult Reliance engineering staff for proper design requirements.

Horizontal Lifeline System Components

The Skyline™ Horizontal Lifeline System for Looped Rebar consists of the following standard approved and compatible components:

- 1 ea. Model 6000 Skyline™ Shock Absorber (stainless steel)
- 1 ea. Model 6050 Steel In-Line Cable Clamp (zinc plated carbon steel)
- 10 ea. Model 6062 ½" bow shackles (stainless steel)
- 1 ea. Model 6090 3" Ratchet Assembly
- 1 ea. Model 6092 10' Ratchet Strap, 3" wide
- 2 ea. Model 6155 End Stanchions, 2" square steel tube, 60" high
- 2 ea. Model 6122 2" Ratchet Tie-back Assembly
- 2 ea. Model 6127 15' Ratchet Tie-back Strap, 2" wide
- 2 ea. Model 6170 Looped Rebar Receiver Bracket

The following items represent options that are selected to customize the Skyline™ Horizontal Lifeline System for your particular application:

Cable option (galvanized or stainless steel):

- 1 ea. Model 6070 3/8" – 7x19 IPS galvanized wire rope

or

- 1 ea. Model 6072 3/8" – 7x19 stainless steel wire rope

User Instructions

6360 Skyline™ Looped Rebar HLL System



Bypass option may require one or more of the following (for some lifelines over 20 feet in length):

- Model 6151 60" Bypass Stanchion, 2" square steel tube
- Model 6178 72" Bypass Stanchion, 2" square steel tube
- Model 6163 84" Bypass Stanchion, 2" square steel tube

The above Bypass Stanchions will also require the Model 6170 Looped Rebar Receiver Bracket to attach the stanchion to the walking/working surface.

The actual selection of components and options for the design of a horizontal lifeline system should only be performed by a Qualified Person, or a state registered Professional Engineer who is experienced in the design and use of safety systems.

The Skyline™ Horizontal Lifeline system is designed for use with the approved, above listed components only. Substitutions or replacements with non-approved components will endanger the system integrity and may affect the safety and reliability of the total system.

Personal Fall Arrest Equipment Used with Horizontal Lifelines

It is of utmost importance in the design of horizontal lifelines to be able to predict the vertical fall arrest forces that will be imposed on a lifeline during a fall. Normally the lifeline will elongate under increasing tension until the horizontal lifeline imposes a 900-lbf. Vertical force on the shock absorbing lanyard and then the lanyard will begin to rip out (or extend in the case of a SRL) until all of the fall energy has been absorbed. For multiple persons this force increases as a multiple of 900-lbs. The shock-absorbing lanyard, therefore, is vital in predicting and limiting horizontal lifeline tension. Only shock absorbing lanyards (or SRLs) with 900 lb. maximum arrest force are allowed for use with this system.

Care should also be used in selecting harnesses for use with horizontal lifeline systems. Due to the HLL sag height, additional distance required for clearance when using horizontal lifeline systems is often the limiting factor in determining whether a HLL system can be used for a particular application. Harnesses with sewn down back pads can limit as much as 1 ft. of back pad slippage during fall arrest, giving additional clearance for safety. If the system will be used where a worker could encounter a head first free-fall, a non-secured back pad can slide down the webbing to the small of the back, allowing the worker to fall out of the harness through the top by allowing the harness straps to slip over the shoulders. For this reason, we recommend the use of full body, crossover or pullover type harness with sewn down or slip resistant back pads for all installations.

Installation Layout Considerations

Most HLL installations consist of either single-span or multi-span systems. Single-span systems consist of two end anchorages with a single HLL lifeline attached between them. Multi-span systems consist of two end anchorages and multiple intermediate (bypass) supports through which the cable passes, but which it is not attached. Normally the bypasses consist of a structure that will allow a lanyard snap to

User Instructions

6360 Skyline™ Looped Rebar HLL System

pass through without allowing the cable to become disconnected. Input energy into an HLL system during fall arrest is usually determined by span length. The longer the span, the farther a person will fall during fall arrest and therefore, the greater the input energy. The more people that fall on a system at one time, the greater the falling weight and this also increases the input energy. In order to limit input energy into a system, one must limit the number of persons on a system and also limit the span length. On the other hand, the cable, having the greatest energy capacity (or ability to absorb energy) of all the components of a system due to its ability to strain under stress, must be long in order to absorb the greatest amount of energy. Therefore, the safest way to rig and assemble a horizontal lifeline system is to use the longest cable length possible with bypass supports located to reduce sub-span length to as short as possible. Only minimum required clearance limits (MRC) should be used to determine maximum allowable line length.

Installation

Installation of horizontal lifeline systems should be done under the supervision of a Qualified Person trained in their function and use. Use only parts that have been qualified as compatible components by Reliance. Install the system only as specified in the system parameter documents prepared by the computer program system. Ensure that the minimum anchorage strength is at least 2 times the anticipated load called out in the system parameter documents. Have the anchorages certified by a qualified person and keep documentation on hand. HLL calculations for minimum required clearance (MRC) are measured below the walking/working surface and assume that the horizontal lifeline is at least 5 ft. above the walking/working surface (unless otherwise specified) in order to limit free-fall to 6 ft. or less as required by OSHA. Always install lifelines horizontally where all end anchorages and bypass supports are at the same elevation. Always install the system per the system parameter documents and NEVER change span length, sub-span length, or number of people allowed on the system. Remember, horizontal lifeline dynamics change with any changes to span length, or number of people allowed on the system. Any changes require a new design, and MUST be approved by a Qualified Person.

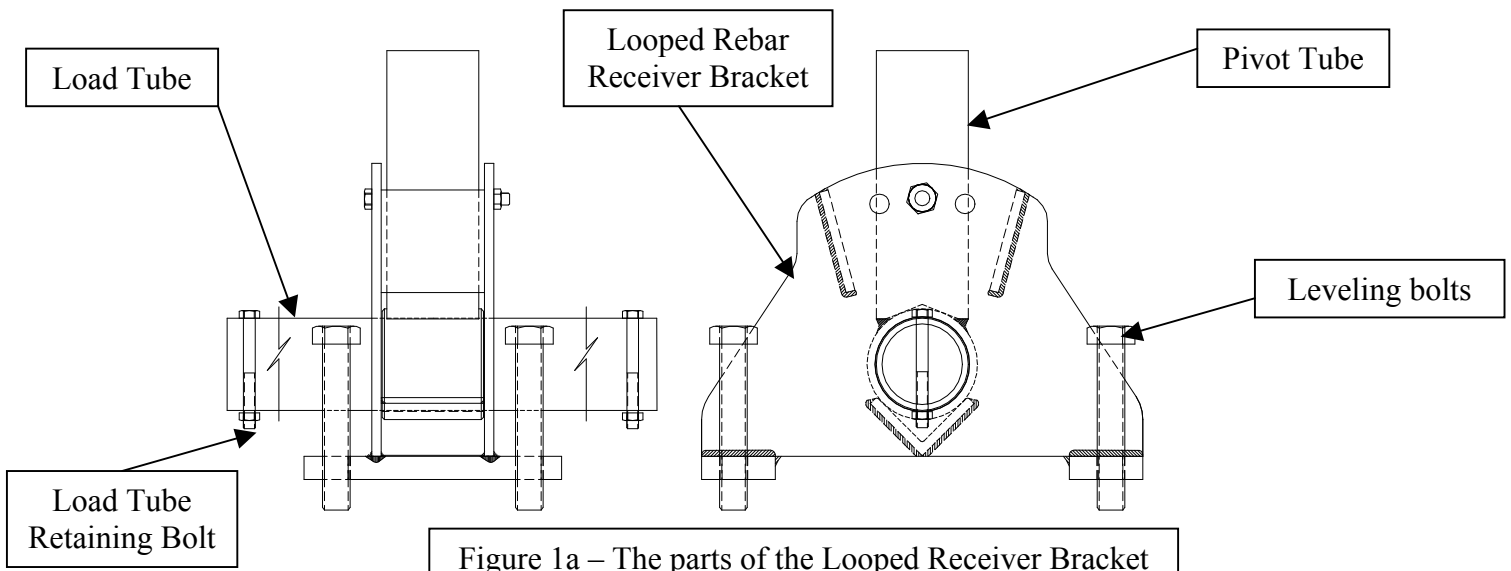

Figure 1a – The parts of the Looped Receiver Bracket

User Instructions

6360 Skyline™ Looped Rebar HLL System

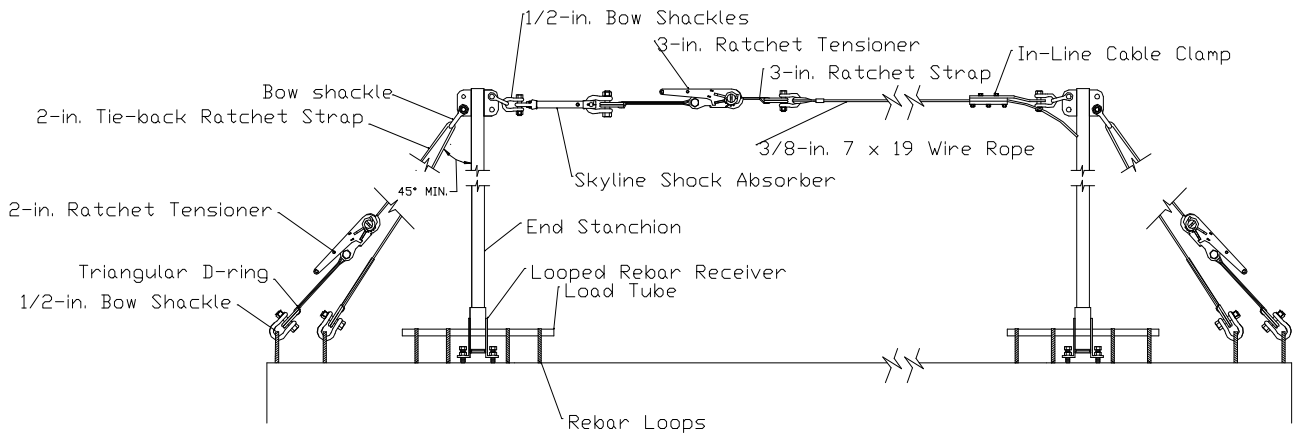

Figure 1b

HLL Installation Procedures

NOTE: Approved fall protection must be worn during Skyline™ lifeline installation at all times. Do not use the horizontal lifeline or its anchorages as personal fall protection anchorages until the system has been completely installed, inspected, and approved for use by a Qualified Person.

To Install the Looped Rebar Receiver

1. Remove the Receiver Load Tube bolt and Load Tube from the Looped Rebar Receiver (see Figure 1a or Figure 1b for parts identification). Place Receiver between rebar loops. Note: Rebar loops must be Grade 40 or Grade 60 rebar, Size 4 (1/2-in.) or larger.
2. Slide Receiver Load Tube back through hole of Receiver Bracket. The adjusting bolts may need to be turned counter-clockwise to lower Receiver Bracket to allow Load Tube to pass under the rebar loops. Replace the bolts in the ends of the Load Tube.
3. Center the Load Tube in the Receiver.
4. Tighten the Receiver adjusting bolts clockwise to begin raising the Receiver.

User Instructions

6360 Skyline™ Looped Rebar HLL System

5. Measure the distance from edge of adjusting bolts to nearest edge of concrete. If distance is less than 3-in., a steel plate with a minimum thickness of 0.25-in. must be placed under the adjusting bolt to prevent the bolt from causing a “compression blowout” during tightening. Each adjusting bolt that is closer than 3-in. to an edge must have a plate underneath (see Figure 1c).

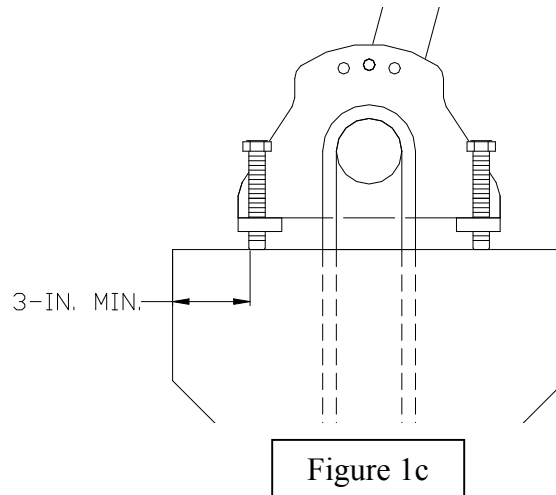

6. Raise Receiver evenly until Load Tube presses firmly against the inside of the rebar loops. Note: A minimum of 4 rebar loops MUST be engaged by the Load Tube.
7. Slide End Stanchion into the Receiver Pivot Tube. Ensure the anchor lugs at the top end of the Stanchion are parallel to the load tube (pointing the direction that the lifeline will be running).
8. Tip Pivot Tube to the desired side of the bridge beam and bolt into place.

To Install the Tie-back Strap Assemblies

9. Attach a 5/8-in. bow shackle to the lowest hole of the end stanchion on the side of the end stanchion head opposite where the horizontal lifeline will attach. Secure bow shackle in place using the nut and safety ring.
10. Attach the 1/2-in. bow shackle to the triangle ring of the 2-in. wide by 15-ft. long Tieback Ratchet Strap. Bolt the Tieback Strap a rebar loop that is located approximately the same distance away from the Looped Rebar Bracket as the end stanchion is tall (for a 5-ft. tall stanchion the selected rebar loop should be located at least 5-ft. away from the bracket). It must be attached on the opposite side from the side the horizontal lifeline will be attached to. Secure in place with the nut and cotter lock ring.

NOTE: The Ratchet Tensioner of the tie-back cable assembly MUST be placed so that the angle formed by the surface of the bridge beam and the tie-back cable is 45° OR MORE when measured from the vertical. This means that the Ratchet Tensioner MUST be attached to a loop of rebar that is located a distance away from the Receiver which is AT LEAST as far away as the Stanchion is tall (for a 60-in tall End Stanchion, the Ratchet Tensioner MUST be attached to a rebar loop located a MINIMUM of 60-in. away from the Receiver to ensure that the tie-back angle is 45° or more when measured from the vertical, see Figure 2).

User Instructions

6360 Skyline™ Looped Rebar HLL System

11. Attach a 1/2-in. bow shackle to the triangle ring of the Ratchet Tensioner and the rebar loop used for tieback. Secure the Ratchet Tensioner to the next rebar loop adjacent to the loop that was used to secure the ratchet strap. **NOTE:** The Ratchet Tensioner and the Ratchet strap **MUST NOT** be attached to the same rebar loop; each **MUST** be attached to their own loop of rebar. Secure in place with the nut and cotter lock ring.
12. Pass the 2-in. Ratchet Strap up through the 5/8-in. bow shackle that is attached to the end stanchion and then thread it into the mandrel of the Ratchet Tensioner and ratchet until tight (see Figure 1b). Verify that the webbing makes **AT LEAST** one full revolution on the mandrel. If it does not, release the load, pull a couple of inches of strap out, and then retighten to achieve the minimum one full wrap of webbing on the mandrel.
13. Repeat Steps 1 through 12 to install the Looped Rebar Receiver for the other end of the lifeline.
14. Repeat Steps 1 through 8 to install Looped Rebar Receivers with Bypass Stanchions at the correct location as required for your particular horizontal lifeline design. If there are **ANY** questions regarding the design or suitability of a horizontal lifeline in a particular situation, call Reliance Engineering at (303) 424-8650, BEORE proceeding with the setup or use of any lifeline.

To Install the Skyline™ Horizontal Lifeline

15. Layout the cable on a flat surface near where the lifeline will be installed (directly below the bridge beam where the stanchions will be or are located) and remove all bends. Inspect cable for crush spots, broken wires, weld strikes, or any other deformity that may affect the integrity of the cable. Damaged cables must be removed from service immediately.
16. Position the eye end of the wire rope so that it is about 7-ft. (see Figure 2) away from the location of one of the end stanchions.

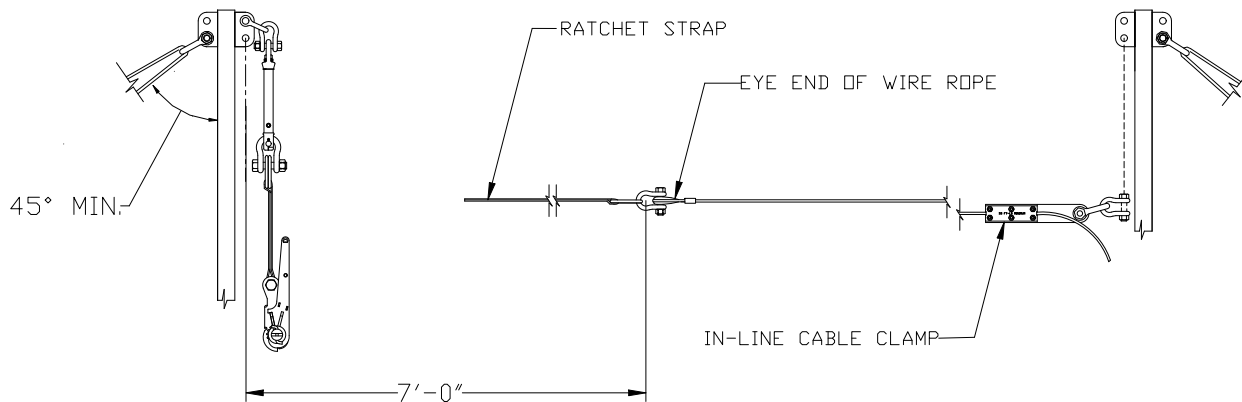

Figure 2

17. Locate and mark the spot on the wire rope where the In-Line Cable Clamp will attach.
18. Remove the 6 bolts and lock washers from the top plate of the In-line cable clamp. Set the top plate aside.
19. On the mark you have measured off, place the wire rope into the grooved lower plate of the In-line cable clamp. Insure that the end of the cable clamp with the hole in it is placed towards the free end of the wire rope (see Figure 2).

User Instructions

6360 Skyline™ Looped Rebar HLL System



Reliance Industries, LLC

20. Twist the wire rope if needed to match the lays and press down into the grooves of the clamp. The wire rope may have to be twisted or untwisted slightly for it to align properly.
21. Place the top plate onto the lower plate, and begin tightening the bolts. Tighten the top plate EVENLY to 35 ft-lb. For more detailed information on using the In-Line Cable Clamp, please refer to the "In-Line Cable Clamp Instruction Manual"(Model # 6050).
22. Attach the bolt of one ½" bow shackle through the hole of the In-line cable clamp. Tighten the nut and secure in place with the cotter lock ring.
23. Insert a second ½" bow shackle through the bow of the shackle that is attached to the In-line cable clamp. Using the shackle bolt, attach the bow shackle to the top hole in the End Stanchion. Replace the nut and cotter lock ring.
24. Attach one ½" bow shackle through the triangular d-ring of the 10' long ratchet strap, and the eye of the wire rope. Tighten the bow shackle nut and secure with the cotter lock ring.
25. Insert a ½" bow shackle through the eye of the Skyline shock absorber and the top hole of the second End Stanchion. Secure the bolt with the nut and replace the cotter lock ring.
26. Remove the clevis pin of the Skyline shock absorber and insert the triangular d-ring of the ratchet load binder into the clevis. Replace the clevis pin and cotter lock ring.
27. Begin lifting the horizontal lifeline cable assembly to its intended position (see Figure 3). If bypass stanchions are being used, the cable must be placed through the center of the bypass fittings before the cable is properly tensioned. Pass the free end of the ratchet strap into the slot of the ratchet. Pull the free end of the ratchet strap to help remove slack from the lifeline cable.

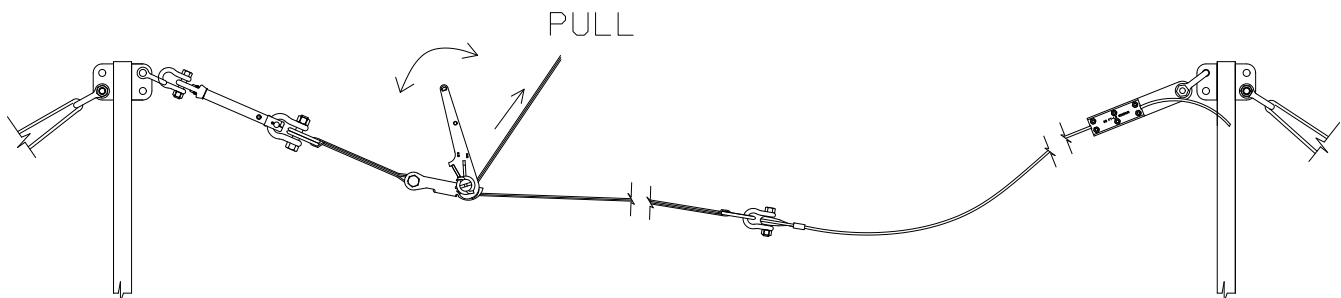

Figure 3

28. While holding the ratchet strap tight, begin tensioning the lifeline, using the ratchet handle.
29. Tighten the ratchet load binder until the line tension just releases the load-indicating washer of the shock absorber allowing it to spin free. This washer is located just under the eye of the shock absorber (see Figure 4). A freely spinning washer indicates that the cable has been pre-tensioned to 1000 lb.

User Instructions

6360 Skyline™ Looped Rebar HLL System

30. Check the webbing of the ratchet strap to see that it has made at least one complete revolution on its mandrel before the correct line tension has been reached. If it has not made a full revolution, release the tension, let 2" to 4" of the ratchet strap to slip back out of the load binder and retighten. The strap should now make at least one full revolution before the lifeline is properly tensioned. At least one full revolution is necessary for the tensioner to reach the maximum load without slipping.

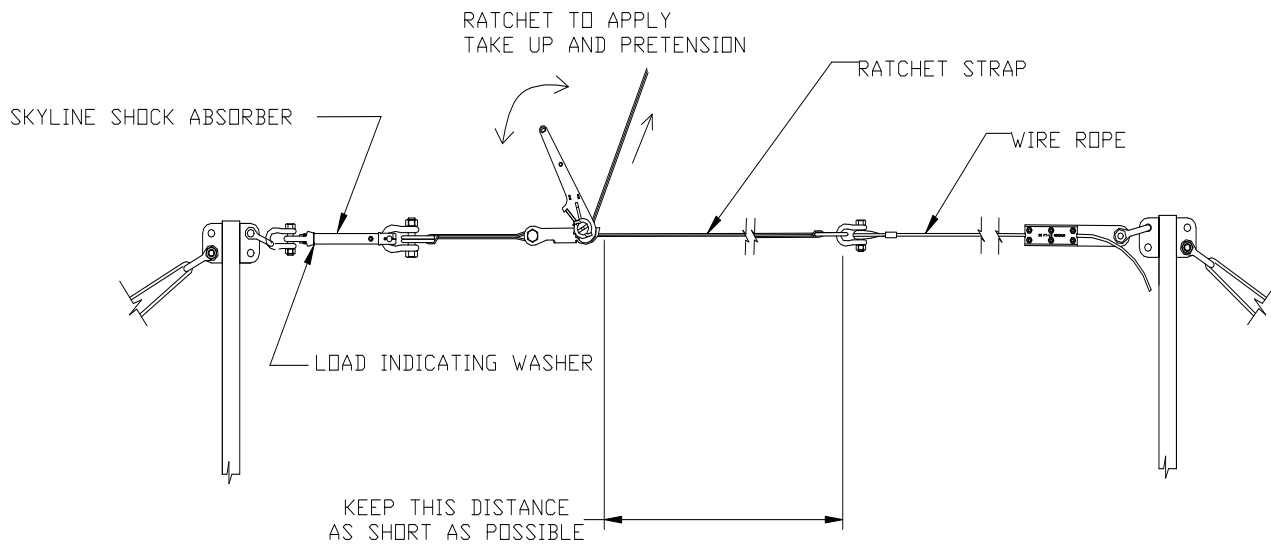

Figure 4

31. Inspect the installation for any defects, such as missing parts, damage, proper anchorage strengths and configuration, proper pre-tensioning, proper cable alignment, proper elevation, defective or non-compatible components. **DO NOT** authorize system use if any defects or discrepancies are found. Check system installation parameters with system installation parameter documents to assure that the correct installation has been performed. (If in question, contact Reliance Engineering for technical support at 303-424-8650.)
32. Once the system passes all checks by the competent person, the system may be approved for use, and labeled with a permanent identification tag referencing the following information:
- Identification number that will reference the original computer generated design parameter documents.
 - Date of installation.
 - Total authorized span length and sub-span length.
 - Total number of people allowed on the system at one time.
 - The minimum required clearance (MRC) below the walking/working surface.
 - The anticipated maximum line tension.
 - The required cable pre-tension (normally 1000-lbs.)
33. A separate tag should also be added indicating date of last inspection by the competent person.

User Instructions

6360 Skyline™ Looped Rebar HLL System



The Skyline™ Horizontal Lifeline pre-tension should be checked prior to each use by inspecting the load-indicating washer on the Skyline™ Shock Absorber for freedom of movement (see Figure 4). If the washer does not spin freely, the lifeline tension must be increased using the 3-in. Ratchet. Ratchet the strap tighter until the load-indicating washer spins freely again.

WARNING: Rebar Loop Systems are typically used in bridge construction. When installing systems on bridges over existing highways and roadways that are in use, the potential for impact between a moving vehicle and a worker hanging below the bridge beam is high. Therefore, always use the height of the moving vehicle for determining the minimum required clearances, not the elevation of the ground below.

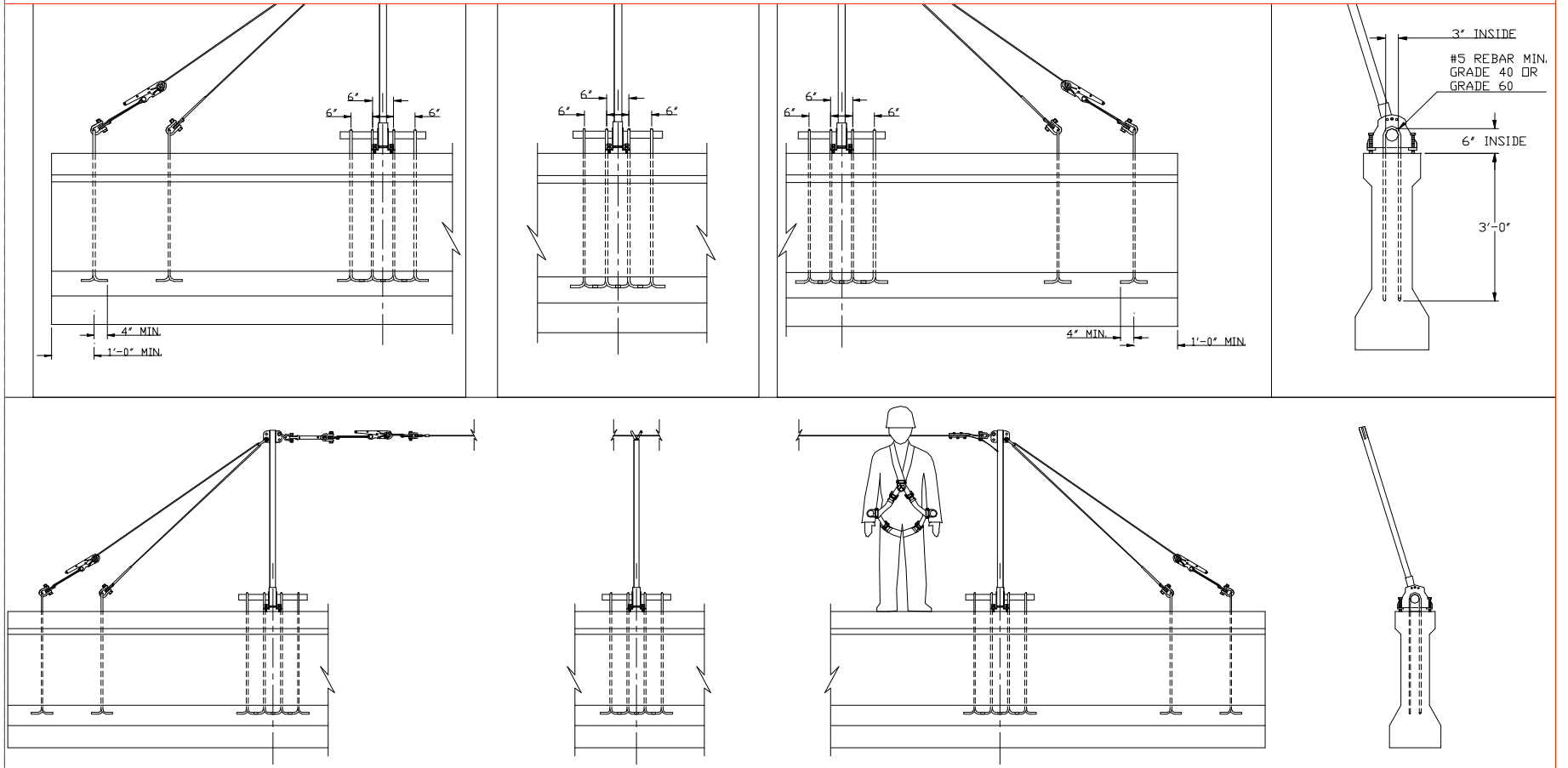

NOTES: L1 L2 L3 L4 L5 L6 L7 L8 L9 L10 L11 L12	REV	REVISIONS DESCRIPTION	 RELIANCE INDUSTRIAL PRODUCTS DENVER, COLORADO	ITEM#	PART#	DESCRIPTION	QTY.		
					TITLE DESCRIPTION				
					FINISH	TOLERANCES UNLESS OTHERWISE SPECIFIED			
					FINISH	0.0000±.0005, 0.000±.005, 0.00±.01			
					MATERIAL	REFENCE # PROJECT			
					MATERIAL	PROJECT			
					DATE	BY	PART #	PART	REV
					DATE	BY			REVISION
					FILE				
					FILE				
					SCALE	SCALE	SIZE	SIZE	SHEET SHEET

Figure 5 – The above drawing shows the typical layout for a Looped Rebar Stanchion System. If your jobsite is setup differently than that shown above, contact Reliance Engineering at (303) 424-8650.

User Instructions

6360 Skyline™ Looped Rebar HLL System



Training

It is the responsibility of the employer to train all workers prior to using this system (per OSHA 1926.503 (a)(1)). The employer shall provide a training program for each employee who might be exposed to fall hazards. The program shall enable each employee to recognize the hazards of falling and shall train each employee in the procedures to be followed in order to minimize these hazards.

The employer shall assure that, as necessary, each employee has been trained by a competent person qualified in the following areas:

- a. OSHA regulations governing the use of horizontal lifelines.
- b. Ability to recognize potential fall and workplace hazards.
- c. Method of inspection of safety equipment.
- d. Rescue procedures.
- e. Installation and removal techniques.

Planning for Rescue

Prior to system use, a rescue plan must be prepared, the workers must be trained in its use, and the rescue equipment must be on hand to implement it in case of a fall.

Typical rescue plans include (but are not limited to) the following items:

1. List of equipment that must be readily accessible in the event of an emergency and the names of those workers certified to use or operate that equipment.
2. Emergency contact phone numbers (ambulance, hospital, fire department...) and a means to contact them (cell phone, emergency radio).
3. List of employees on the site, and the specific tasks they will perform to effect the rescue.

Qualified Persons trained in rescue planning and implementation should only undertake the design and installation of horizontal lifeline systems. It is of the utmost importance to identify a method of rescue from a horizontal lifeline after a fall has occurred, and have the means to effect the rescue on hand. In some situations it may be possible to use the horizontal lifeline itself as an anchorage capable of use for rescue. However, in some situations, it is possible that the horizontal lifeline will come to rest at a level below the walking/working surface making it impossible to be used as a suitable anchorage for rescue. For this reason, always install rescue anchorages to rigid structures for attaching hoists or other retrieval equipment at locations that can be reached by rescue personnel. Note whether rescue must be up or down. If you rescue upward, anchorages must be high enough to raise the fallen worker above the walking/working surface. Individuals who will be using the horizontal lifeline must be trained in the rescue plan and have the equipment on hand to implement it in an emergency. In case a worker has been injured or is unconscious, always consider the evacuation method and path to be used after the worker has been retrieved.

Contact Reliance Engineering for help in identifying possible methods of rescue and rescue planning.

User Instructions

6360 Skyline™ Looped Rebar HLL System



Inspection

Prior to each use, the worker must inspect the system for any physical damage, wear, corrosion, or malfunctioning parts. Check the shock absorber for deployment by looking to see if the black slide bearing under the shock absorber eye is exposed. Once the shock absorber is deployed, its energy capacity is used up, and it cannot be reset. If the shock absorber deploys, the entire system has seen a fall arrest load and must be removed from service until it is inspected by a competent person who either replaces or repairs and re-certifies the components for use on the system. Once deployed, shock absorbers are not re-usable, and must be replaced. If an inspection reveals a problem or unsafe condition, remove the entire system from service until it can be re-certified by a competent person.

The worker, who must also check the pre-tension prior to each use, must inspect all system components. For permanent systems, a formal inspection must be carried out a minimum of once each year, and be formally documented and kept on file with the system parameter documents.

Servicing

A qualified person trained in the inspection and servicing of system components must carry out servicing of this system. The company's safety officer should maintain a record log of all servicing and inspection dates. The system and all components must be withdrawn from service if subjected to fall arrest forces. Those components may be returned to service only after being re-certified by a qualified person. Only original Reliance equipment replacement parts are approved for use in this system. Contact Reliance Engineering with questions and when in need of assistance.

User Instructions

6360 Skyline™ Looped Rebar HLL System



Warnings and Limitations

Proper care should always be taken to visually scan the work area prior to use. Remove any obstruction, debris, and other materials from, and beneath the work area that could cause injuries or interfere with the operation of this system. Be cautious of swing fall hazards if working horizontally to the side of the lifeline. Always use the shortest lanyard length possible to connect to the lifeline. Be aware of the movements of others on the lifeline at the same time, knowing that if they fall, the sudden motion in the lifeline could pull others off balance. When working at a fixed area, tie off to other suitable overhead anchorages if they exist, allowing the lifeline to be occupied by fewer people.

Users should be familiar with pertinent regulations governing the use of this system and its components. Only trained and competent personnel should install and supervise the use of this system.

Do not exceed manufacturers' recommended span length or maximum number of people on the same lifeline as listed on either the tag attached to the specific horizontal lifeline system, or in the lifeline parameter data sheets.

Do not use these components with any other horizontal lifeline material. Only 3/8 – 7x19 IPS or stainless steel wire rope is allowed, due to its high-energy capacity.

Use only Reliance supplied or qualified compatible components.

If you have any questions regarding the correct installation or use of this product DO NOT USE. Contact Reliance Engineering at Ph. (303) 424-8650 or Fax (303) 424-8670.

User Instructions

6360 Skyline™ Looped Rebar HLL System



Inspection Log for HLL Systems

Company: _____ Location: _____ Date: _____
 Job Site: _____ HLL Log No.: _____ System No.: _____

Is this system used as described in the HLL Log No. _____ to conform to design document criteria? _____

Describe non-conforming conditions in the boxes below:

Inspection Criteria	Missing Parts	Labels Readable	Corrosion	Deformed Parts	Cracked Parts/ Broken wires	Excessive Loading
HLL Identity Tag?						
HLL Shock Absorber Label?						
HLL Shock Absorber?						
Rigging Screw?						
End fittings? (combo clamp, etc.)						
Shackles?						
Wire Rope?						
Webbing Strap?						
Ratchet Tensioner?						
Load Rings?						
Anchorage Lugs?						
Bolted Anchor Clamps?						
Stanchions?						
Stanchion Receivers?						
Tie Back Straps?						

Is Shock Absorber pre-tension set correctly? _____

Has a Rescue Plan been prepared? _____

Is Rescue Equipment on hand? _____

Have workers been trained in the Rescue Procedures and been given a copy of the Rescue Plan? _____

Skyline™ Horizontal Lifeline Diagram

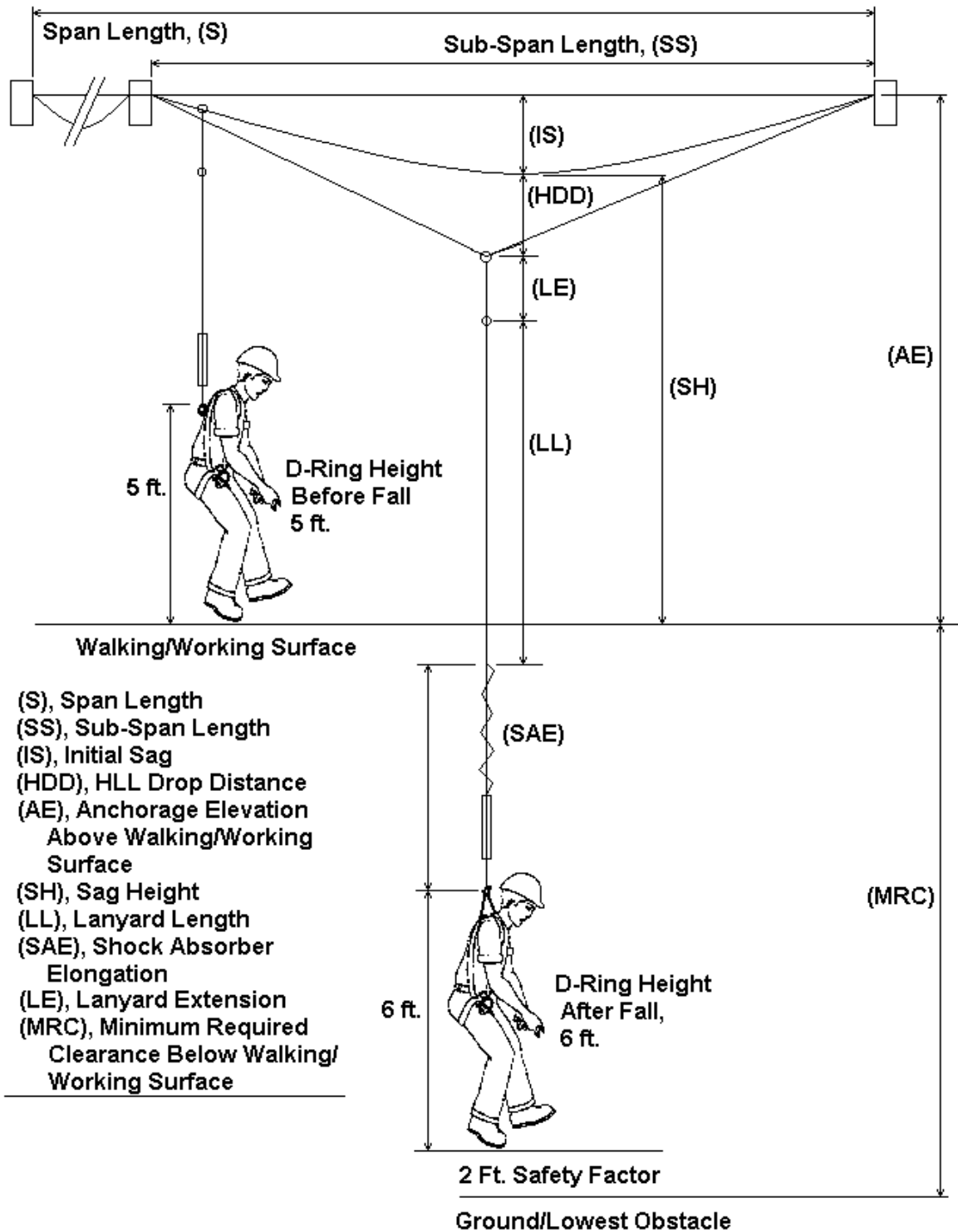

- (S), Span Length
- (SS), Sub-Span Length
- (IS), Initial Sag
- (HDD), HLL Drop Distance
- (AE), Anchorage Elevation Above Walking/Working Surface
- (SH), Sag Height
- (LL), Lanyard Length
- (SAE), Shock Absorber Elongation
- (LE), Lanyard Extension
- (MRC), Minimum Required Clearance Below Walking/Working Surface